

6 DEALER MANUAL FOR M500 (MM G520.250.C)



CONTENT

| | | | |
|------------------------------------------|----------|-------------------------------------------------------|-----------|
| 6.1 Introduction | 2 | 6.3.2 Install drive unit to connection interface..... | 6 |
| 6.2 Specifications | 3 | 6.3.3 Cabling..... | 7 |
| 6.2.1 Outline and geometric size..... | 3 | 6.3.4 Bash Guard and Cover Installation..... | 8 |
| 6.2.2 Surface..... | 4 | 6.3.5 Chain Wheel Installation..... | 9 |
| 6.2.3 Storage Information..... | 4 | 6.3.6 Crank Installation..... | 9 |
| 6.3 Drive Unit Installation | 5 | 6.3.7 External Speed Sensor Installation..... | 10 |
| 6.3.1 List of Tools to be used..... | 5 | 6.4 Maintenance | 11 |

6.1 INTRODUCTION

- **Appearance**



- **Product Model**

MM G520.250.C

- **Scope of Application**

i Only apply to electric powered bicycles, and specifically designed or licensed for Pedelec. It is suitable for mountain bikes. It should not be used for competition or other commercial purposes.

- **Identification**



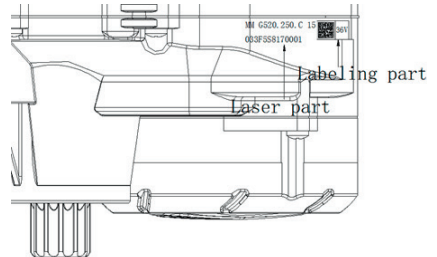

There are the unique identification of the product on the housing, as shown in figure:



Note: Contents in Label part are important information of this product. Please keep them properly for updating of software or providing after-sales service.

6.3 DRIVE UNIT INSTALLATION

6.3.1 List of Tools to be used

| Use of the Tools | Tools |
|---------------------------------------------------------------------------------------------------------------------------------------------|---------------------------------------------------------------------------------------------------------|
| <p>To fasten screw onto the frame adapter and the drive unit</p> <p>To fasten screws on the crank Mounting Down cover for motor</p> |  Internal hex wrench |
| <p>To fasten screws on the motor cover and cable cover</p> |  T10 Torx screw driver |
| <p>To fasten or remove lock nut on the chain ring</p> |  Special tools |
| <p>To fasten nuts onto the frame adapter and the drive unit</p> |  Socket spanner |

6.3.2 Install Drive Unit to Connection Interface

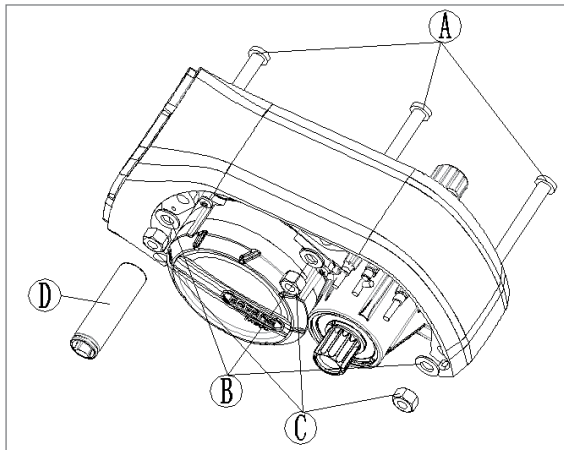
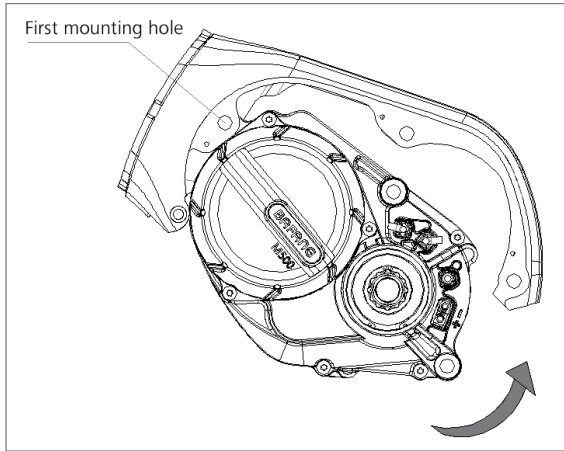

- A M8 bolt
- B M8 flat washer
- C M8 Lock ring
- D Standard tool

1) Align the three mounting holes of the drive unit with the mounting holes in the bike frame. From the right of the bike frame insert three special M8 bolts into the mounting holes in the bike frame and the drive unit.

2) From the left, fasten the three M8 Locknuts (13*13) with flat washer on the bike frame.

The size of the standard tool for our company: outer diameter 17.7 and length 63. Tightening torque: 35 Nm. Requirements for the tools: Outside diameter is less than 20 mm and length is greater than 35 mm.

6.3.3 Cabling

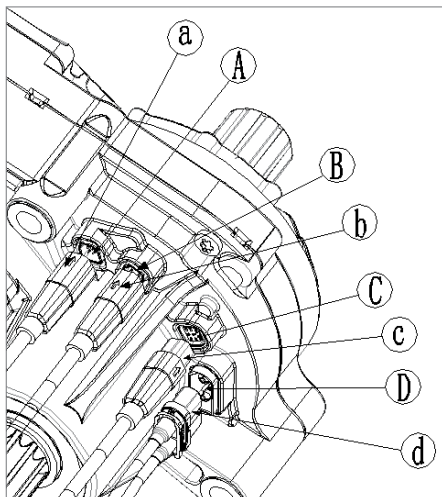

- Ⓐ Male eight-pin connector at the drive unit
- ⓐ Female eight-pin connector at the front BUS cable
- Ⓑ Male six-pin connector at the drive unit
- ⓑ Female six-pin connector for other device
- Ⓒ Female eight-pin connector at the drive unit
- ⓒ Male eight-pin connector rear BUS cable
- Ⓓ Male connector for power supply at the drive unit
- ⓓ Female connector for power supply at the battery

First link the female connector (8 pin) from EB-BUS a to the male connector (8 pin) at the drive unit A. Then link the male connector (8 pin) from EB-BUS c to the female connector (8 pin) at the drive unit C, finally link the power connector together. (Link 6 pin EB-BUS to drive unit this is based on customer functional requirements)

6.3.4 Bash Guard and Cover Installation

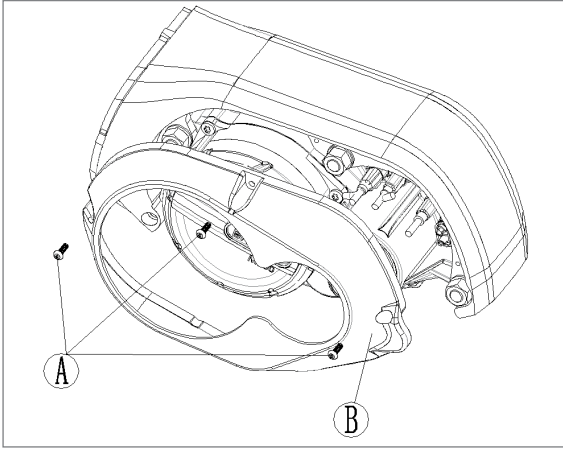

- A Hexalobular socket pan head screw M3*8
- B Covering case

Use T10 Torx screw driver to tighten 3 M3*8 screws through hole sites on the covering case to the connection interface, with tightening torque at 1 N.m.

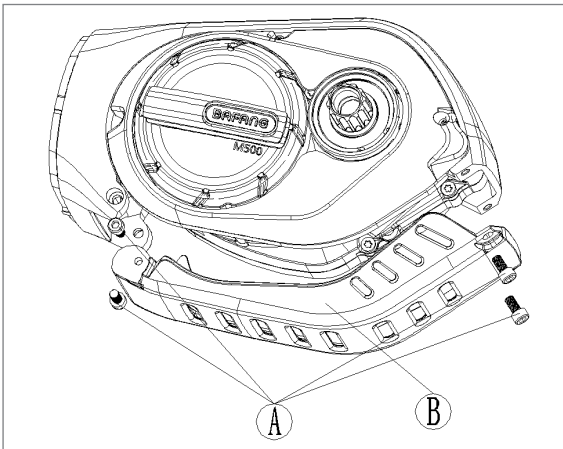

- A Hexagonal socket head cap screw M5*8
- B Bash guard

As shown in the figure, use internal hexagonal wrench to tighten 2 M5*8 screws through hole sites on the bash guard to the connection interface(right side as shown in the figure), with tightening torque at 4 N.m. Then, use internal hexagonal wrench to tighten 2 M5*8 screws through hole sites on the connection interface to the bash guard(left side as shown in the figure), with tightening torque at 4 N.m.

6.3.5 Chain Wheel Installation

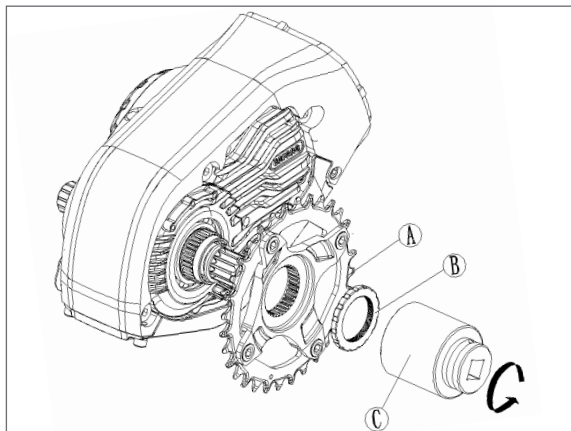

- A Chain wheel (Chain wheel shall be made according to orders of the customers)
- B Lock ring
- C Dedicated tool

Put the chain wheel onto the spline shaft of the drive unit. Use a dedicated tool to fasten the lock ring onto the spline shaft. Torque: 35 Nm.

6.3.6 Crank Installation

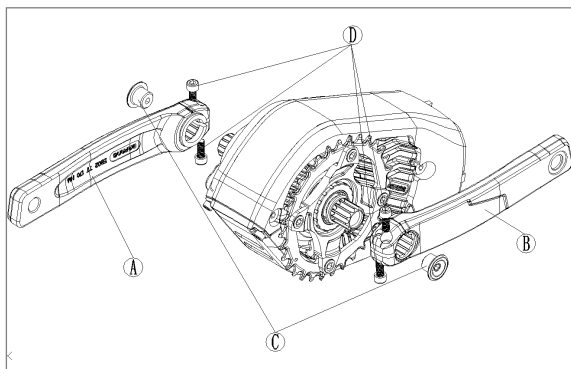

- A Left crank
- B Right crank
- C Screw (for the crank)
- D Hexagonal socket head cap screw M6*20

Mount right crank on the right shaft, with internal hex wrench fasten the lock screws C on the shaft (torque 1.5 N.m) . with inner hex wrench fasten two M6 * 20 hexagon socket cap screws alternately (note: do not from unilateral one-time fasten), torque for wrench is 15N.m. same way will left crank mount on the shaft (guarantee left and right crank parallel).

6.3.7 External Speed Sensor Installation

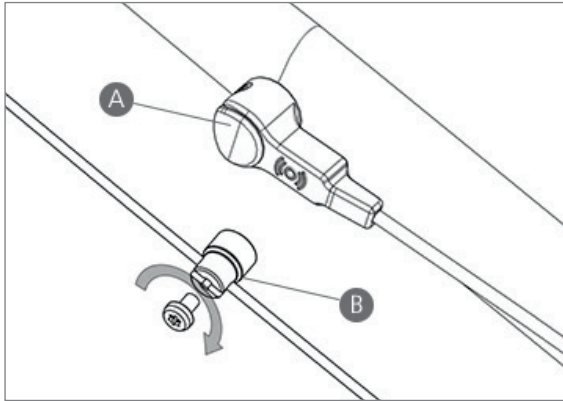

- A Speed sensor
- B Magnet for the speed sensor

Fasten the mounting screws through the speed sensor and with a cross screwdriver. Tightening the speed sensor onto the frame. Then place the rubber seal on the speed sensor hiding the screw. Torque requirement: 1.5-2 N.m.

(Note: Please make sure the gap between the speed sensor and the magnetic unit is between 10 and 20 mm. When the magnet is not the correct distance, this can cause Error 21)

Now place the magnet on the spoke of the wheel ensuring it is aligned to the middle of the speed sensor. And with a star key tighten the magnet in place. Torque requirement: 1.5-2 N.m.

6.4 MAINTENANCE

- Maintenance must be carried out by authorized personnel with the correct equipment.
- Do not disassemble the motor.
- Do not use thinners or other solvents to clean the components. Such substances can damage the surfaces.
- Avoid water submerging, to keep the components protected.
- Avoid using high-pressure cleaning jets.
- For prolonged storage, turn off the battery and avoid storing near heat sources.